



FABLESS CHIP COMPANY

UNLOCKING THE POWER OF LIGHT

SEP 2024

WHY US

Nicslab,
developing electronics and
photonics integrated circuits for
future optical solutions in data
center, instrumentation,
telecommunication, AI and
quantum computing

Our solution controls the light to
process information, transfer data
faster and analyze signal more
efficiently.

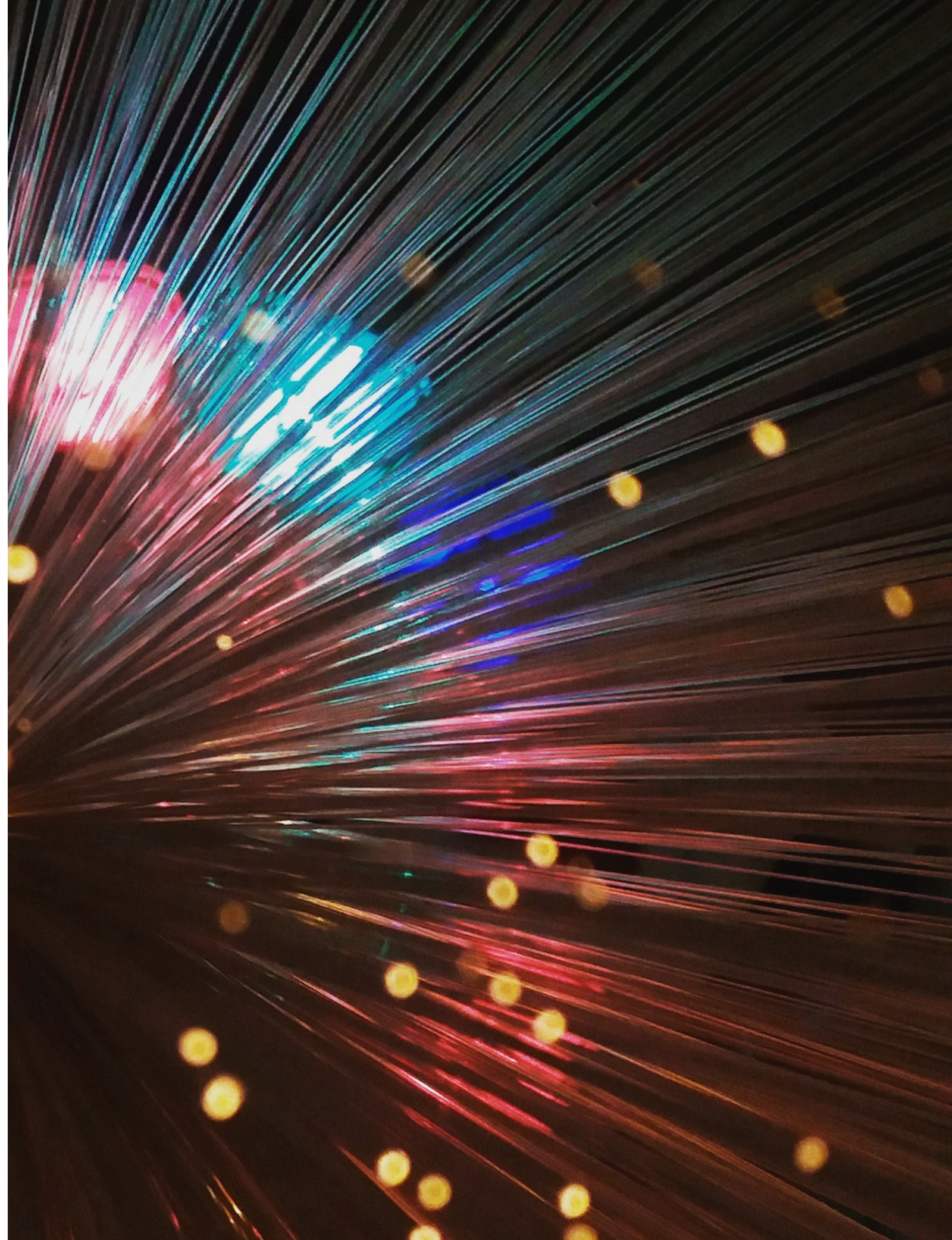

VISION

To be a global semiconductor company, creating technology that transforms the future and make a positive impact on humanity.

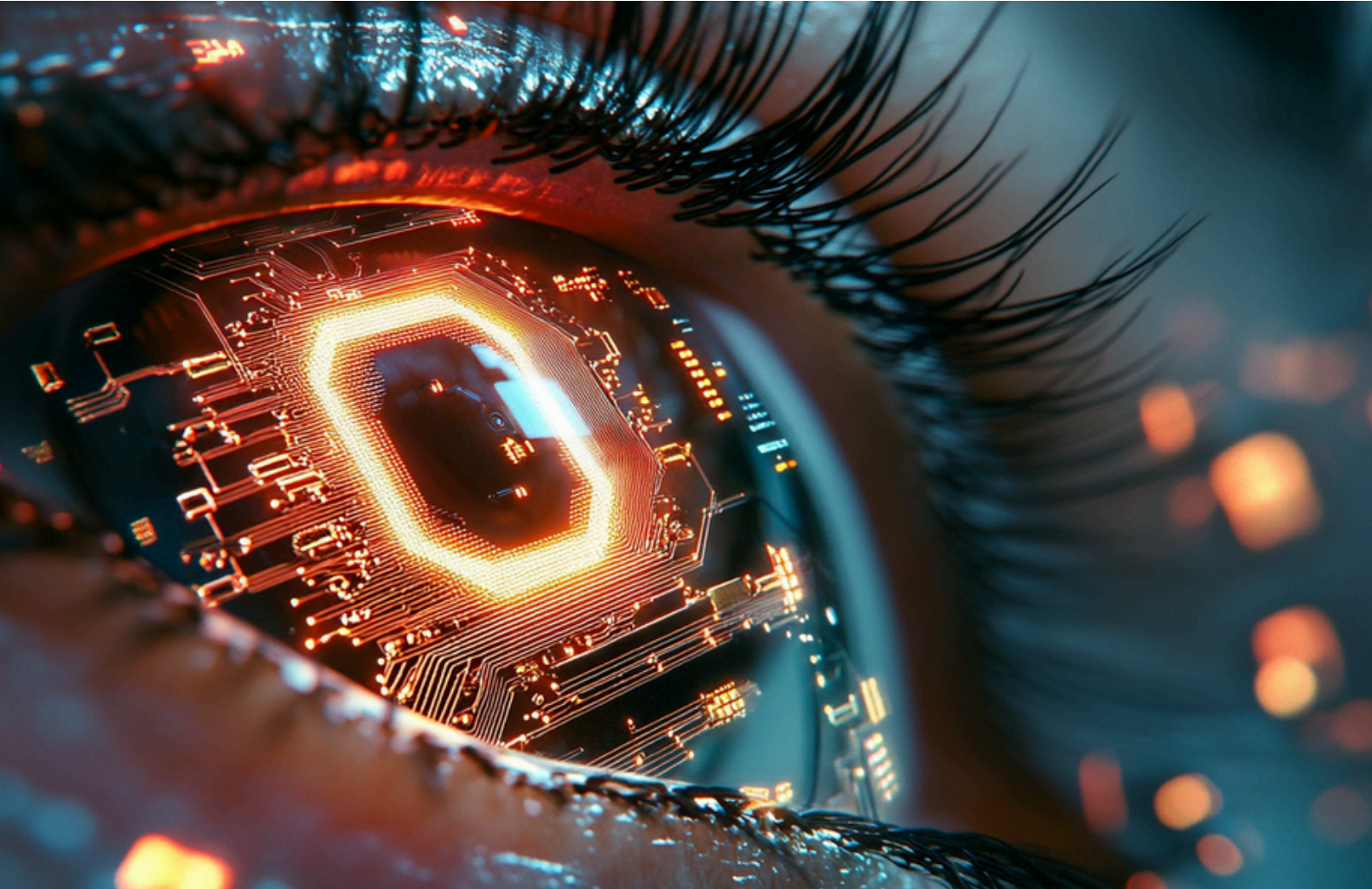
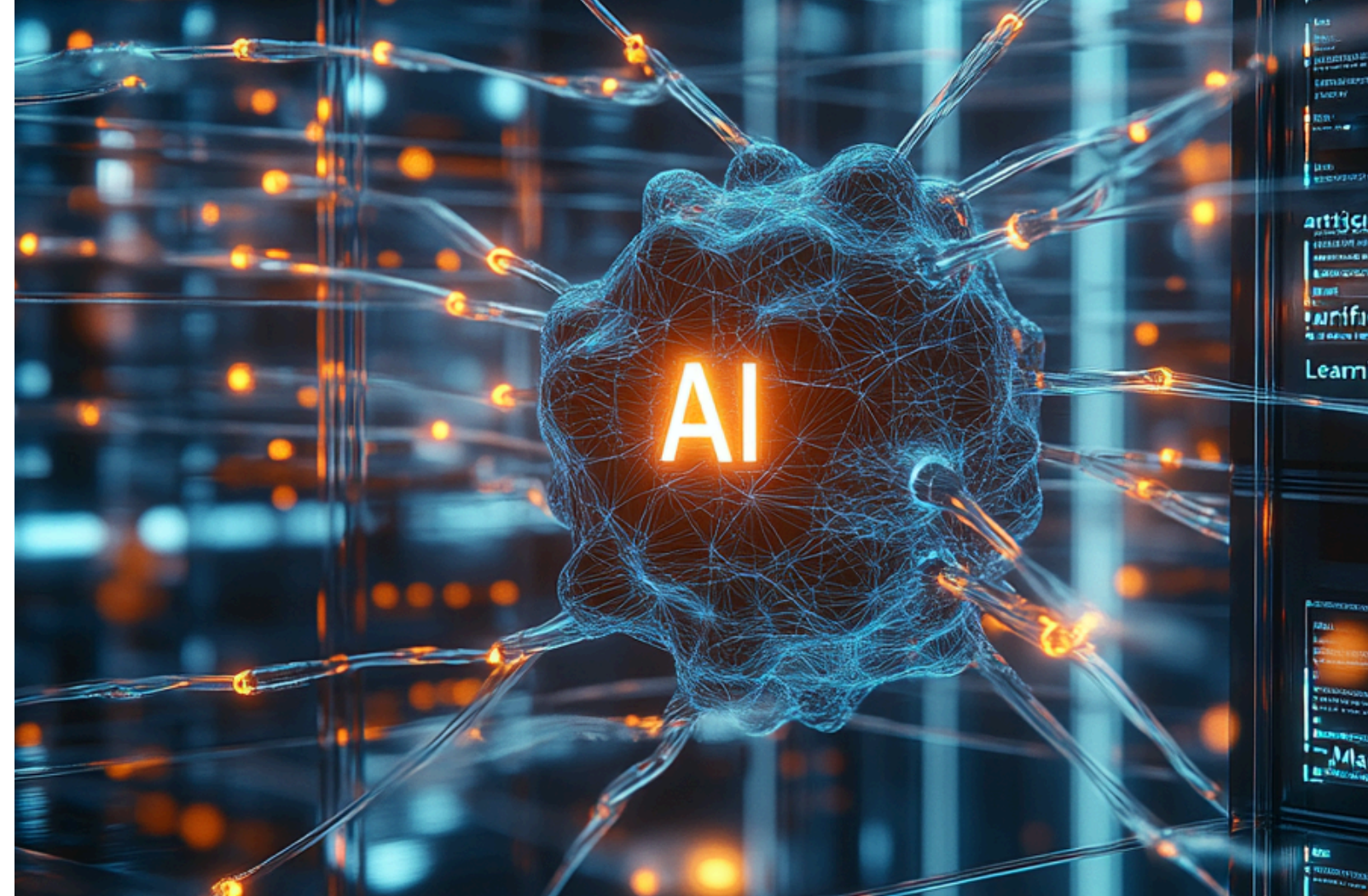

MISSION

We design and deliver cutting-edge hardware, software, and chip solutions for electronic-photonic integration, focusing on customer satisfaction and innovation.

FABLESS IC SERVICES

We offer custom photonic chip design, electronic chip and printed circuit board (PCB) design, electronic-photonic integration, as well as complete system design services. Our experienced team of engineers can provide you with high-quality, cost-effective solutions for all of your needs.



Photonic Integrated Circuits (PIC) Services

- Custom PIC design service
- Layout service using product development kit (PDK)
- Design assistance

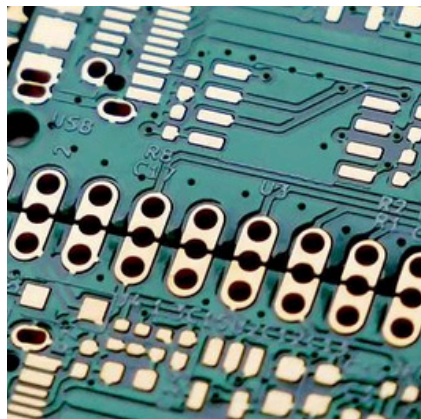

Electronic Integrated Circuits (EIC) Services

- Custom EIC design service
- Design assistance
- Field Programmable Gate Array (FPGA) design
- Full range of PCB design services,

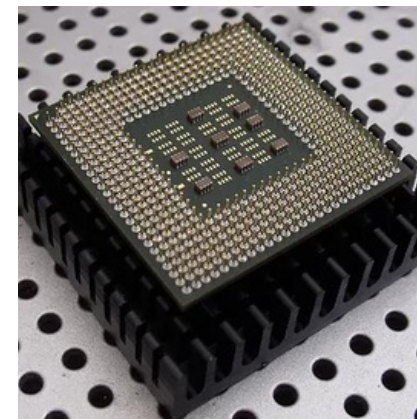

Electronic Photonic Integration

Our technology combines electronic and photonic components on a single chip to create a hybrid/heterogeneous system that can process both electronic and photonic signals.

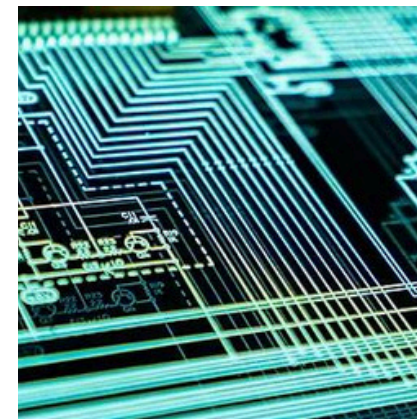

Complete System Design

Design a system that meets your unique needs and requirements. We will help you identify the right hardware, software, databases, and data structures to ensure that your system is scalable, flexible, and reliable.

GETTING STARTED



XDAC-120 channels

We have built a complete scalable source measurement system experience. Whether you're sourcing devices, measuring parameters, automating experiments or analyzing data, you will find better control, flexible output range, with high scalability.

There are two ranges of product: XPOW and XDAC which each has 8, 40, and 120 channels. Every box of channels can be daisy chained for modularity tested up to 1000 channels.

This table below is for general guidance for selecting product according to your specifications and needs.

Specifications	XPOW	XDAC		
		MUB	U	DIFF
Processor	8-bit AVR RISC-based microcontroller	Quad Core Cortex 64-bit ARM v8		
Voltage & Current Resolution	16-bit	16-bit	16-bit	16-bit
Output	Unipolar	Bipolar	Unipolar	Differential
Output Range	0 - 34 Volt, 0 - 300 mA	±16 Volt, ±500 mA	0 - 34 Volt, 0 - 300 mA	±18 Volt, ±500 mA
Intuitive GUI	Yes	Yes	Yes	Yes
SCPI command support (Python, C#, Matlab, and LabVIEW)	Yes	Yes	Yes	Yes
Sharing Ground	Yes	Yes	Yes	No
Premium Range	0 - 5 Volt, 0 - 10 Volt, 0 - 20 Volt, 0 - 200 mA, 0 - 100 mA, 0 - 50 mA	±2.5 Volt, ±5 Volt, ±10 Volt	0 - 5 Volt, 0 - 10 Volt, 0 - 20 Volt, 0 - 200 mA, 0 - 100 mA, 0 - 50 mA	±2.5 Volt, ±5 Volt, ±10 Volt
Port	USB	Ethernet		

OEM/ODM SOLUTION

We provide chip-scale and OEM/ODM technologies that will enable applications in quantum photonics, phase array microwave photonics, AI, transceivers, programmable photonics, and LIDAR.

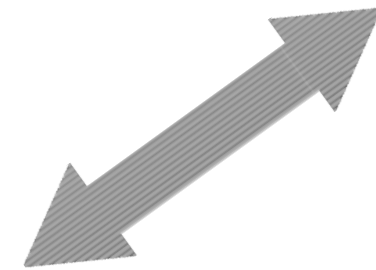

Applications:

- Quantum computer based photonic
- Phase array microwave photonic
- AI photonic
- Photonic transceiver
- Photonic switch
- Field programmable photonic arrays
- LIDAR

CONTROL &
MEASURE



Modulators

Photonic Chip

Laser

Photodiodes

COSTUMER DEMOGRAPHIC IN DIFFERENT COUNTRIES

Trusted by technology leaders in 15+ countries.

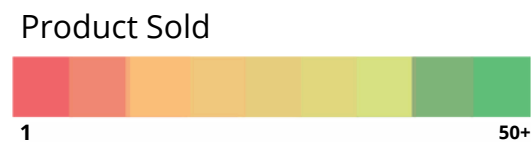
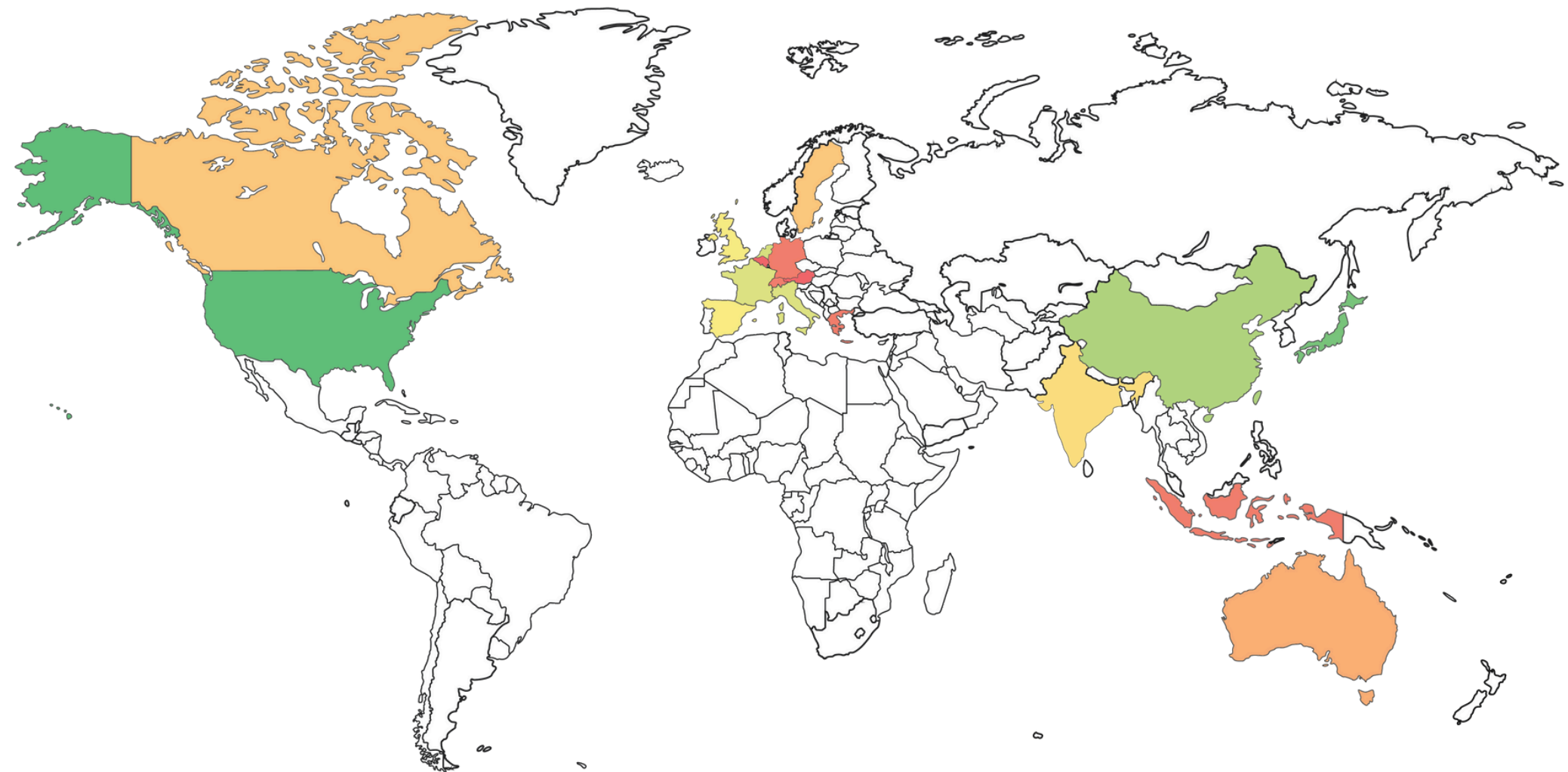

CUSTOMERS

Trusted by technology leaders in 30+ companies



Instrumentation



AI & Quantum



Telecommunication & Data Center

REVIEWS

“ This product is incredibly convenient and straightforward. We especially appreciate the real-time voltage display alongside set values in the GUI, the efficiency of ribbon cable connections for swift board/chip swapping, and compatibility with Python for parameter setting and querying

*Gregory P. Sercel & Nemanja Jovanovic Ph.D,
Caltech/JPL NASA*

“ We like the large channel capacity with higher power per channel. The software is pretty good in terms of the GUI and interface to get started testing the devices. The customer support has been excellent.

*Dr. Raj B. Patel, Future Leader Fellow,
Imperial College London*

“ We like the number of channels, ease of use, and integration with our Python code.

*Kumar Piyush & Ashitosh Velamuri, Research Scholars,
IIT Madras*

“ I appreciate the Python API, the seamless plug-and-play functionality, ease of use, reliability, and quality - reasons why I've chosen to use it for several projects.

*Kees Franken,
Fellow in Applied Physics, Harvard University*

“ I use a 3-channel XPOW as bias controller for an IQ optical modulator and it works wonderfully. Because XPOW is so compact, I can package it in the same box as my modulator. The software user interface is simple yet so good and intuitive. These features are critical for me in the device prototyping project I have with a few defense contractors in the US. I ended up purchasing a couple of XPOW units and shipping them to these contractors together with the prototype. It is definitely a powerful solution for the control of optical modulators.

*Dr. David Marpaung,
Professor at University of Twente*

DIMENSION



	XPOW			XDAC-MUB			XDAC-U			XDAC-DIFF	
Number of Channels	8	40	120	8	40	120	8	40	120	8	40
W (mm)	106	232	232	106	232	232	106	232	232	141	232
L (mm)	164+37.68 (Front Board)	333	450	164+37.68 (Front Board)	333	450	186.99+35 (Front Board)	333	450	186.99+35 (Front Board)	450
H (mm)	61.6	102	102	61.1	102	102	91	102	102	91	102

SET-UP DIAGRAM

The XPOW/XDAC needs to be connected with DC power supply then you can plug into the Device Under Test (DUT) or multiconnector first. The voltage/current can be controlled through Graphical User Interface (GUI) or SCPI command via USB/Ethernet port.

DC input maximum voltage depends on the type of XPOW/XDAC. For unipolar (U), the DC maximum input voltage is 36 V. For bipolar (B), the maximum voltage is ± 18 V. For differential (DIFF), the maximum voltage is ± 12 V. Typical minimum current to power up is ~ 3 A depend on the channel density.

Please check your DC power supply maximum current. You can directly connect the XPOW/XDAC with your Device Under Test (DUT) with its terminal block (8 channels) or you can use our Multiconnector (40, 120 channels) for easier setup.

In order to select the appropriate platform according to your needs, our team of engineers can assist you.

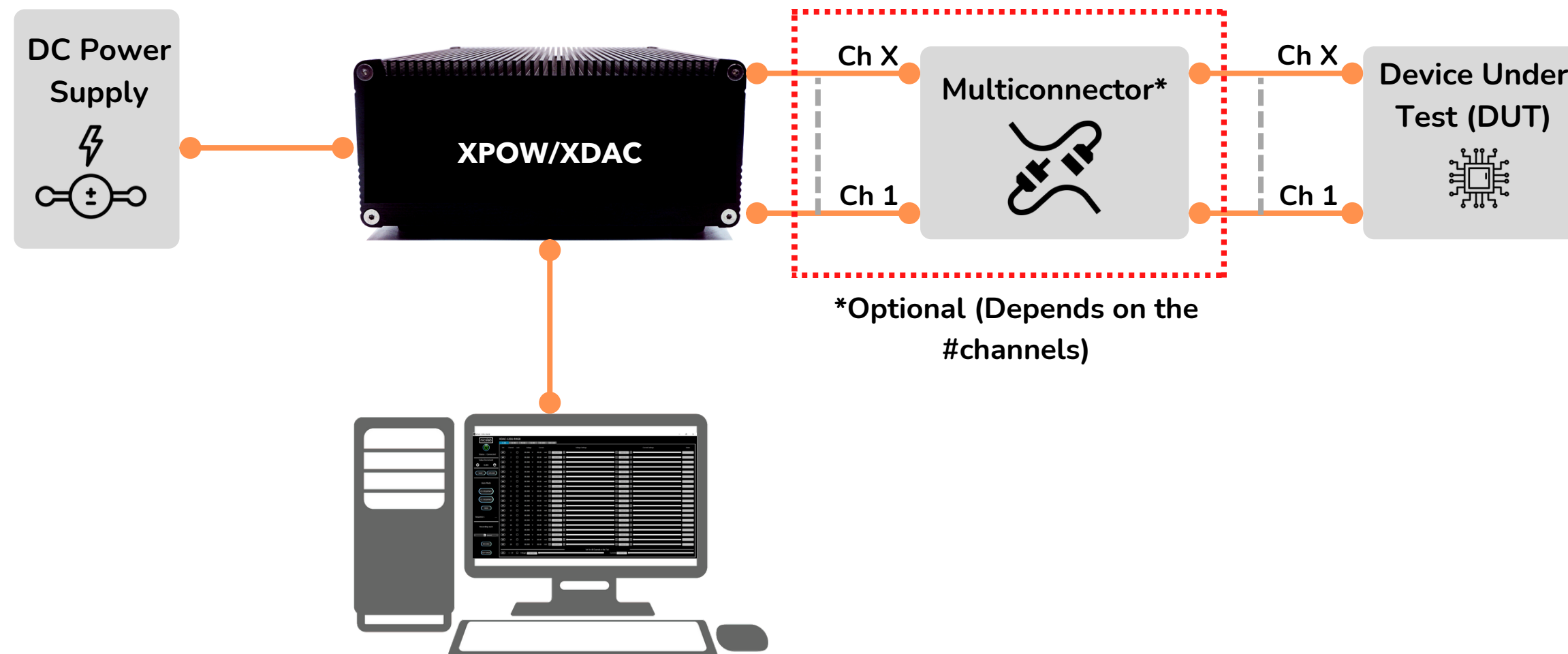

MULTICONNECTOR

Multiconnector (M1, M2, M3, M4, M5, M6) enables your XPOW/XDAC to connect with Device Under Test (DUT) through various kinds of connector. Multiconnector is optional and can be purchased separately.

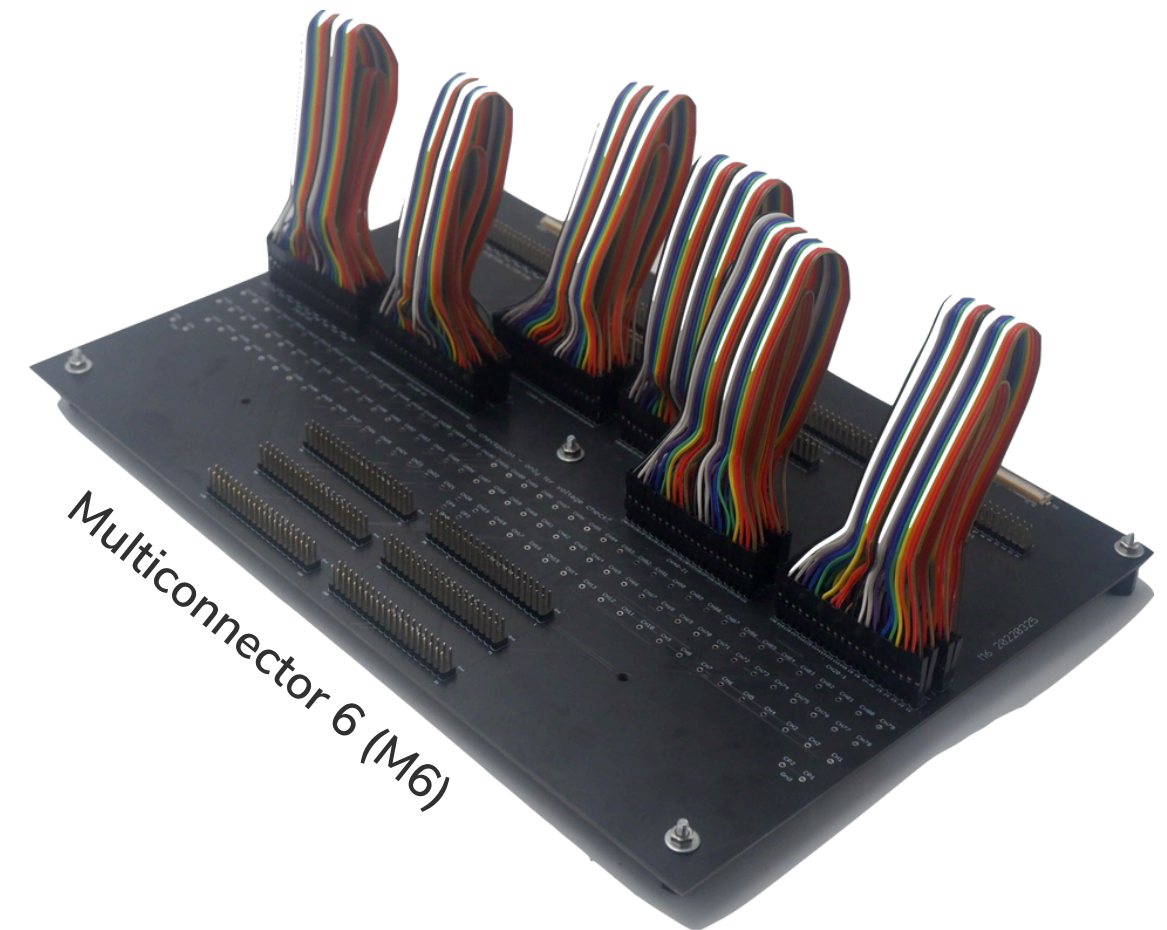

M1

- 40 Channels
- 2xFFC (20, 24, 50 pin)
- 16xSMA
- 2x40 pin 2.54 mm

M3

- 40 Channels
- 2x40 banana 4 mm
- 2x40 pin 2.54 mm

M4

- 40 Channels
- 2xFFC (24 pin, 50 pin, D-Sub 25)
- 2x40 pin 2.54 mm

M2

- 120 Channels
- 3xFFC 50 pin
- 6x40 pin 2.54 mm

M5

- 120 Channels
- 10xD-Sub 25
- 6x40 pin 2.54 mm

M6

- 120 Channels
- 3xFFC 50 pin
- 6x40 pin 2.54 mm

GUI

Our multichannel source measurement system can be controlled directly with GUI or SCPI commands.

The GUI is already included in the product package with essential Basic features. Additional advance features is enabled in Premium features.

We also provide a set of commands and codes template (Premium features) via Python, Matlab and LabView.

Basic Features

- Slider
- Voltage Reading
- Current Reading
- Enable SCPI Command

Premium Features

- Basic
- Notes
- Lock
- Save & Load
- Settings (Voltage & Current Limit, Voltage Range, Reading Speed)
- Record
- Sequence
- Programming Template
- Range Span Configuration



PERFORMANCE TESTING

Example Performance : XDAC-120MUB

- ▶ Longterm Test (25 hours) with static input (1.5V & 150mA)

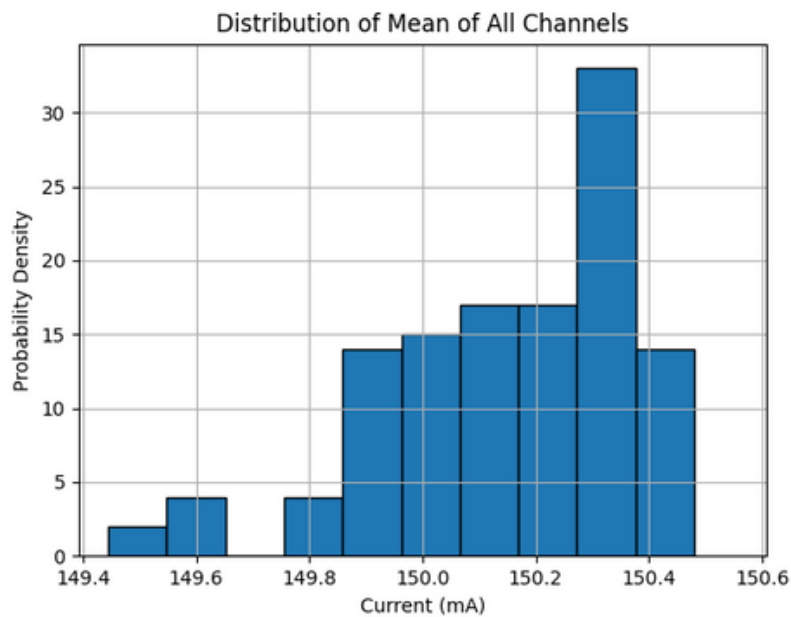
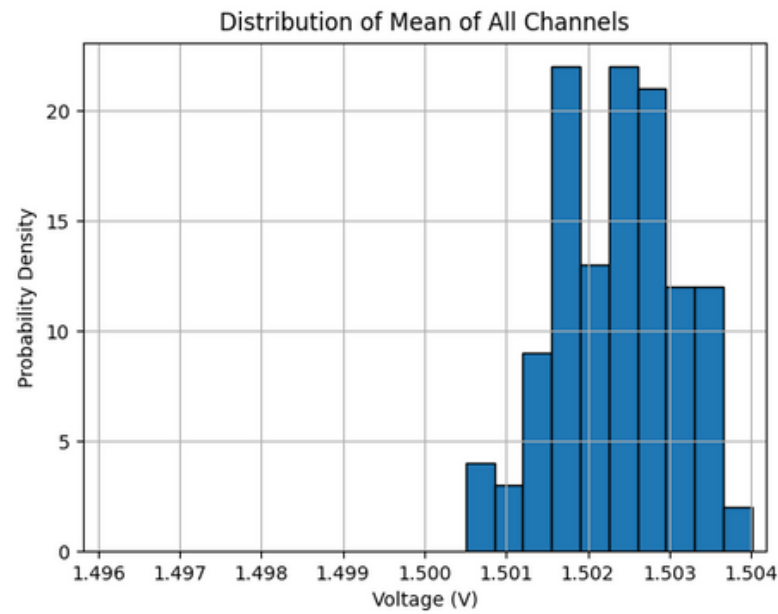

- ▶ Short-term Test CV (14hours) with Dynamic Input ((-4.9) - (-0.2))V and ((0.2) - (4.9))V with step 0.01V

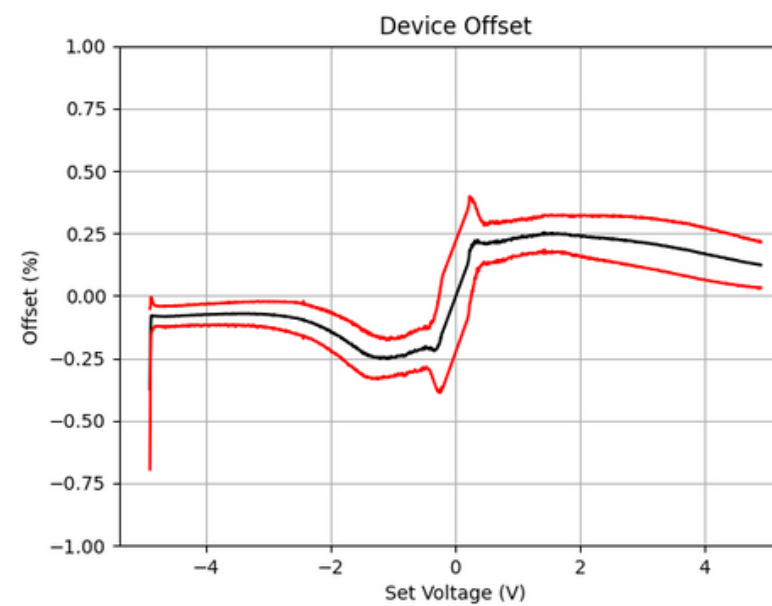
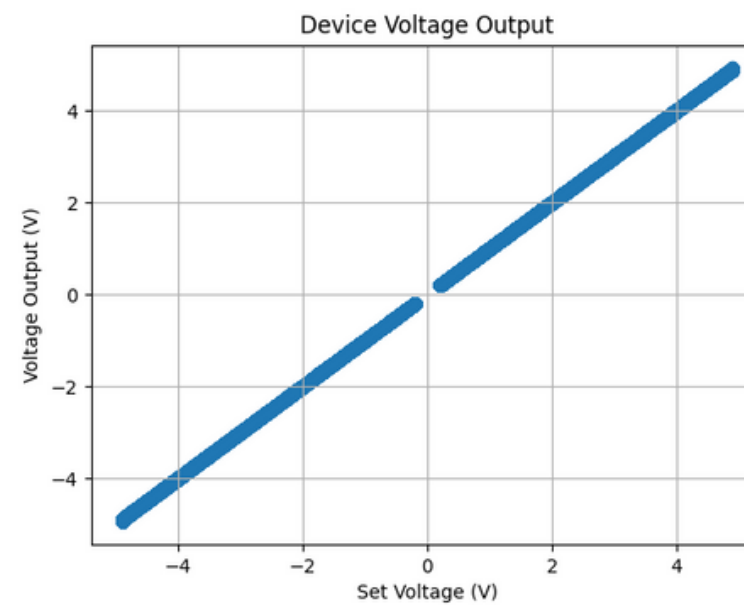

- ▶ Longterm Test (25 hours) with static input (1.5V & 150mA) ((-500) - (-20))mA and ((20) - (500))mA with step 1mA

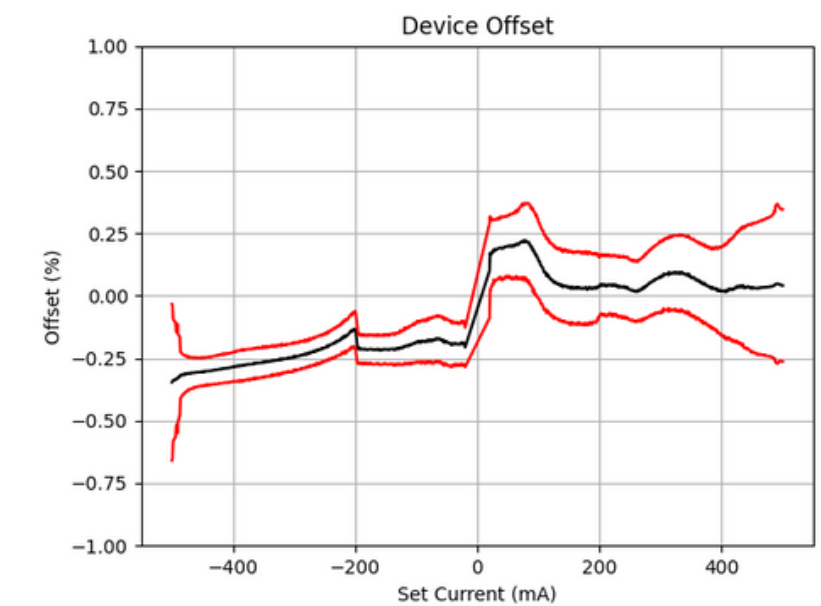
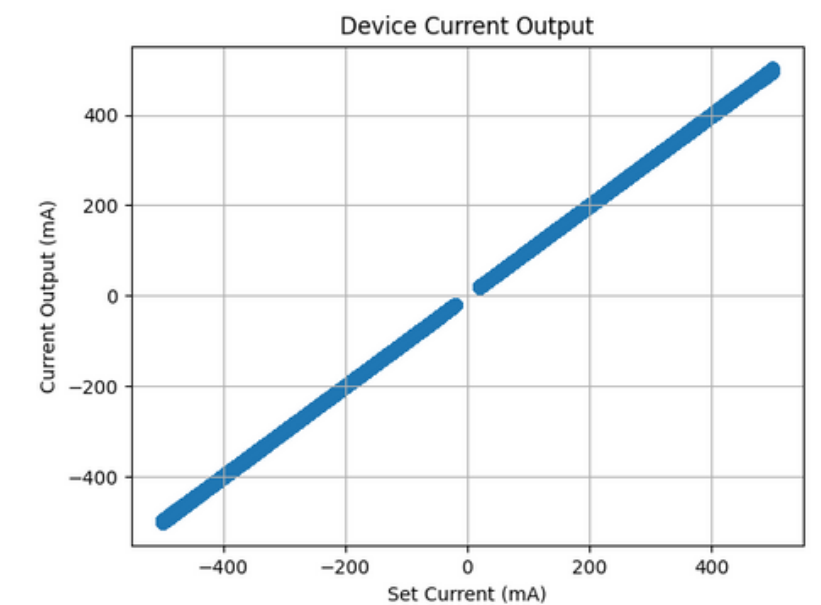

CUSTOM-BUILT SERVICE

We can design a multichannel source measuring system specifically to meet your needs. The customization includes size, connectors, and channel number. Here are some examples of previous custom products:

Custom Type: XPOW-8AX-CCvCV-U-SLIM



Even smaller and lighter than standard XPOW. The specifications of this item are the same as those of its standard equivalent.

Custom Type: XDAC-80MUB-R4G8



Smaller than XDAC-120MUB but larger than XDAC-40MUB. This item is unique because it was created especially to meet specific requirements.

USE CASE 1

Deep Learning Accelerator

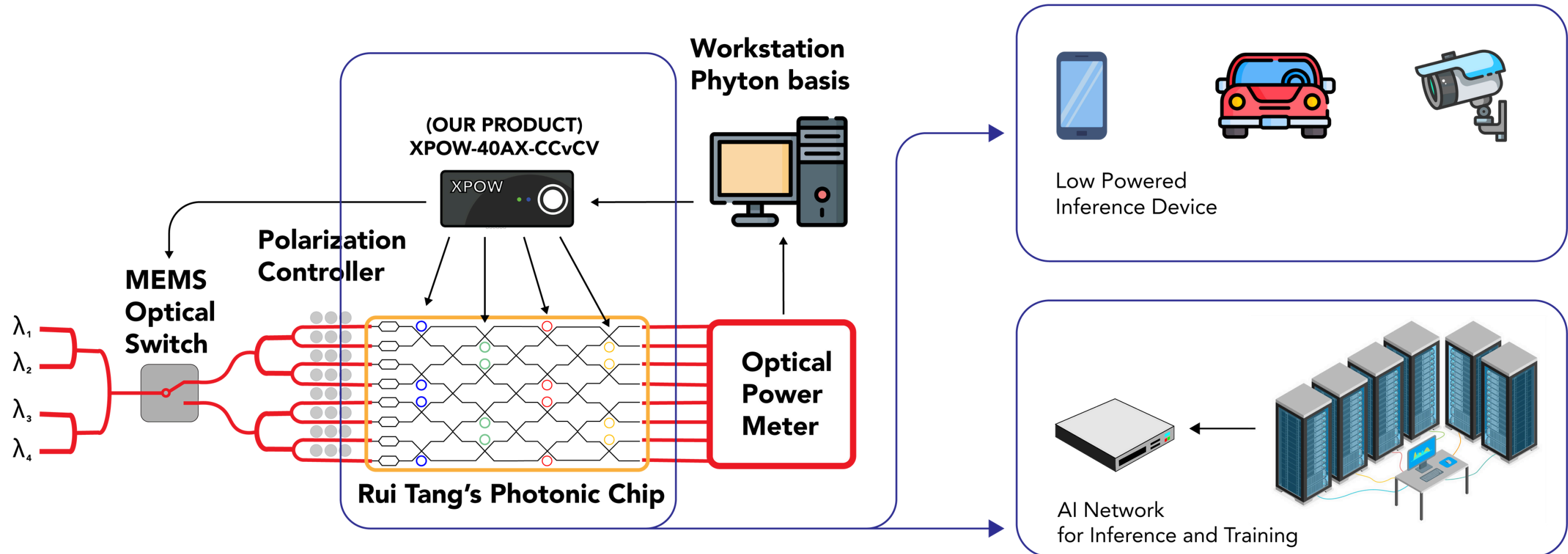

AIST & University of Tokyo

USE CASE 2

Spectrograph for Exoplanet Exploration

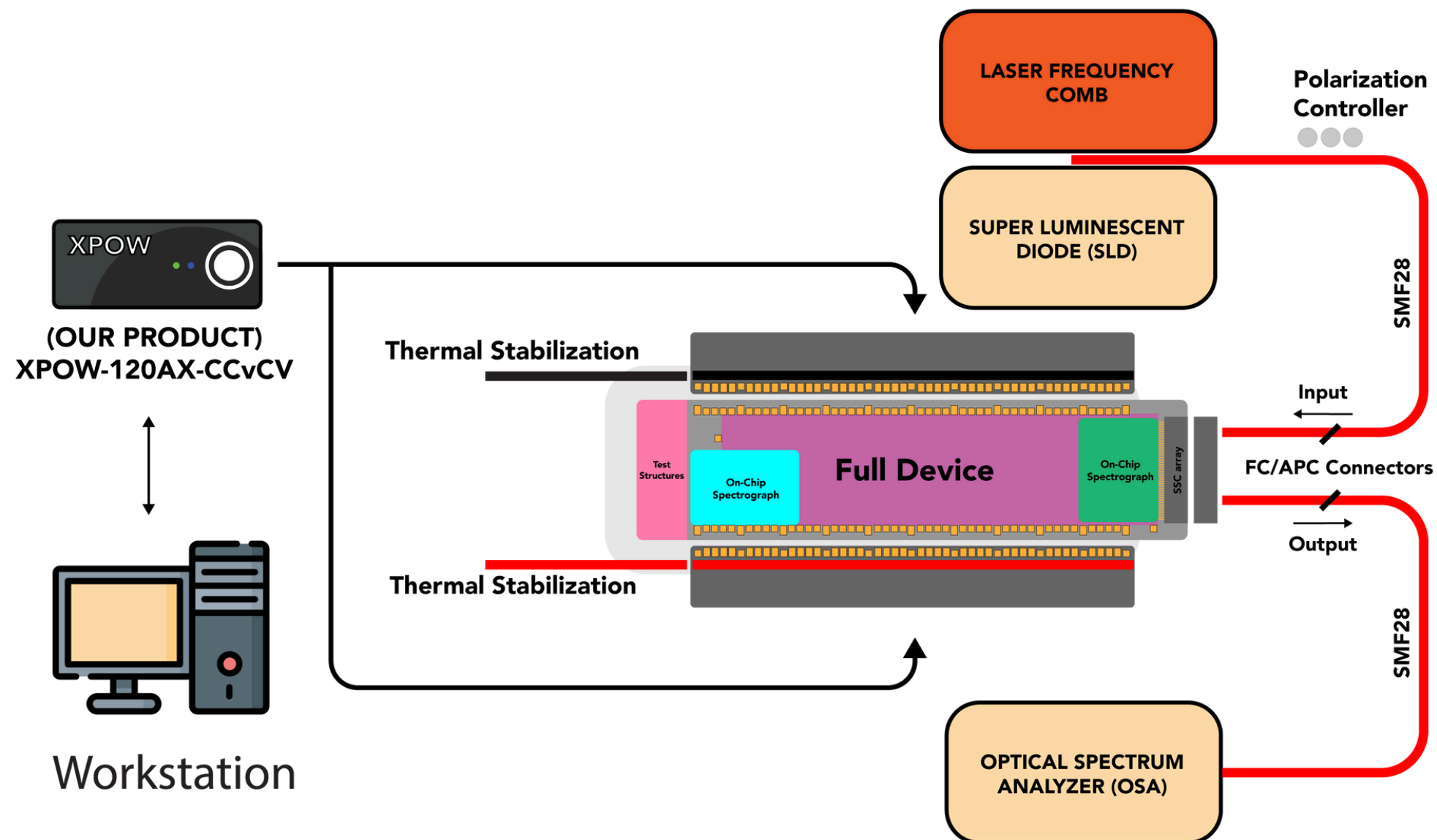

NASA JPL, Caltech, & CNRS France.

USE CASE 3

Photonic Based RF Filter for 5G

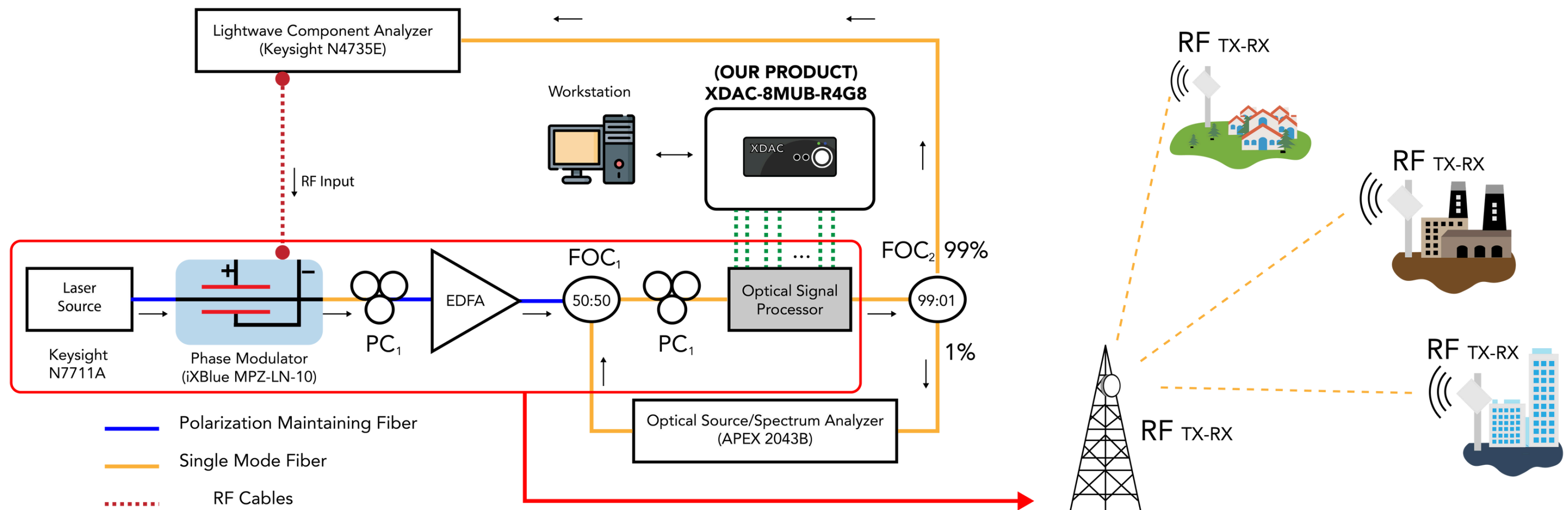

IIT Madras

USE CASE 4

Arithmetic Processor with Photonics

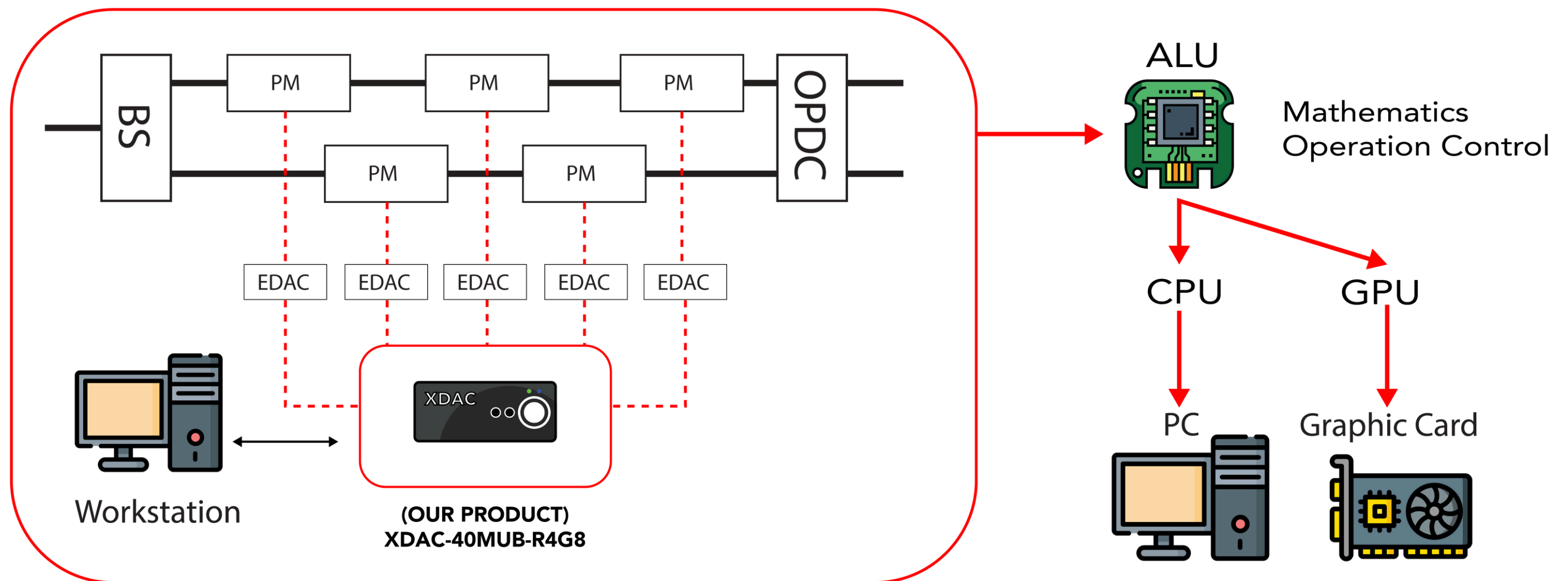

Beijing University of Posts and Telecommunication

USE CASE 5

High-Capacity Fiber Optic Transceivers

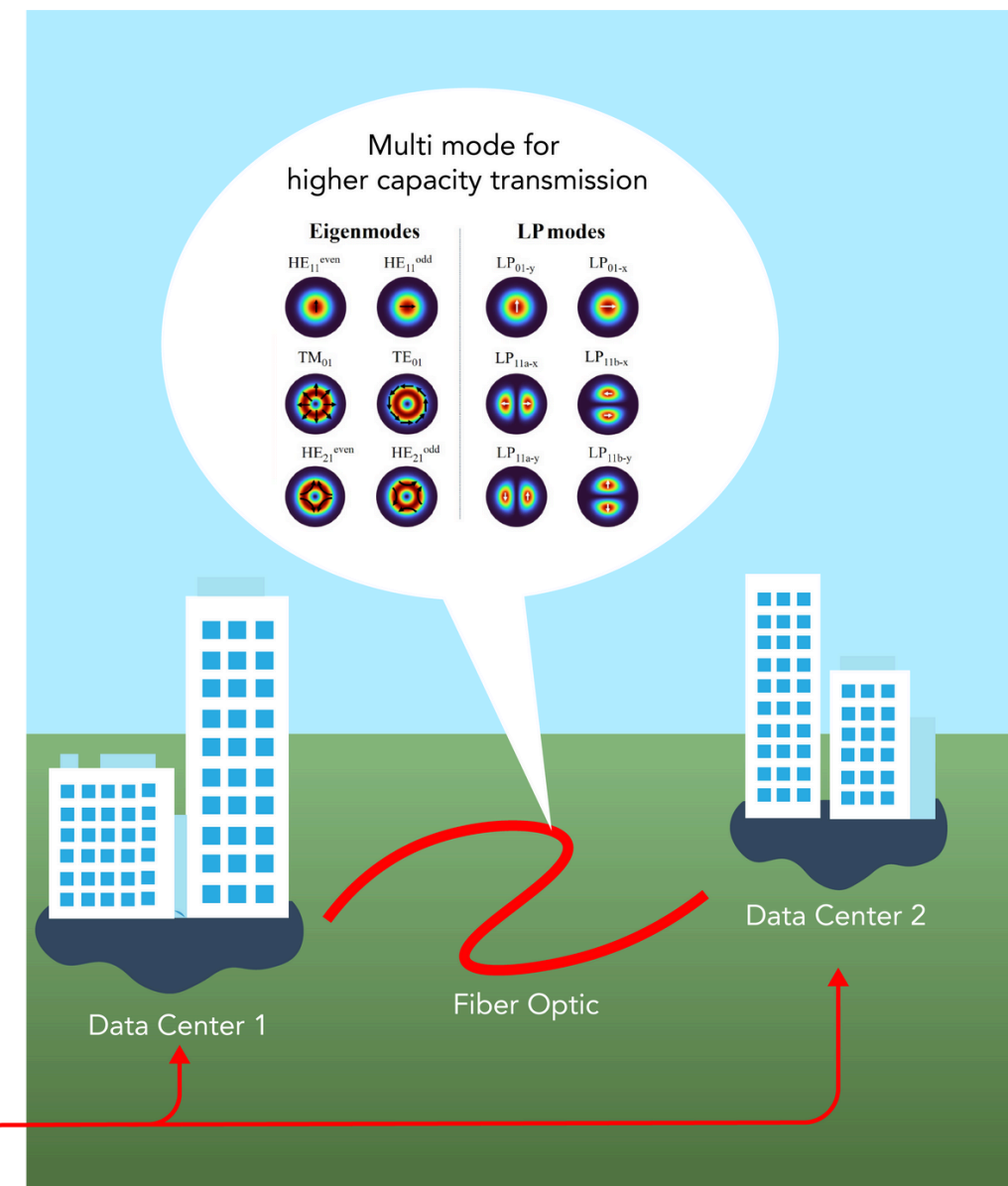
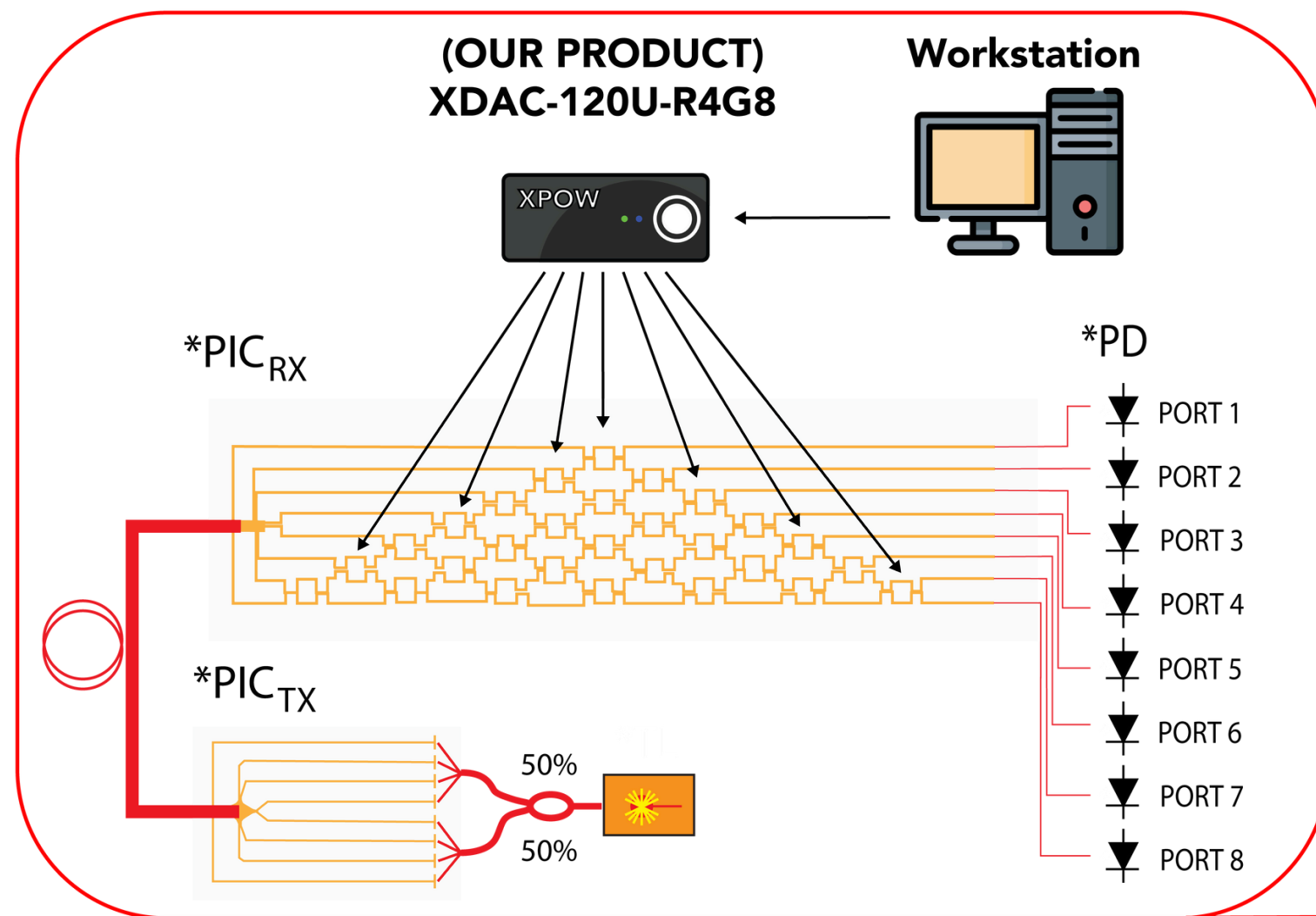

CUHK, HKUST, Tianjin University

USE CASE 6

Photonic Wafer Testing

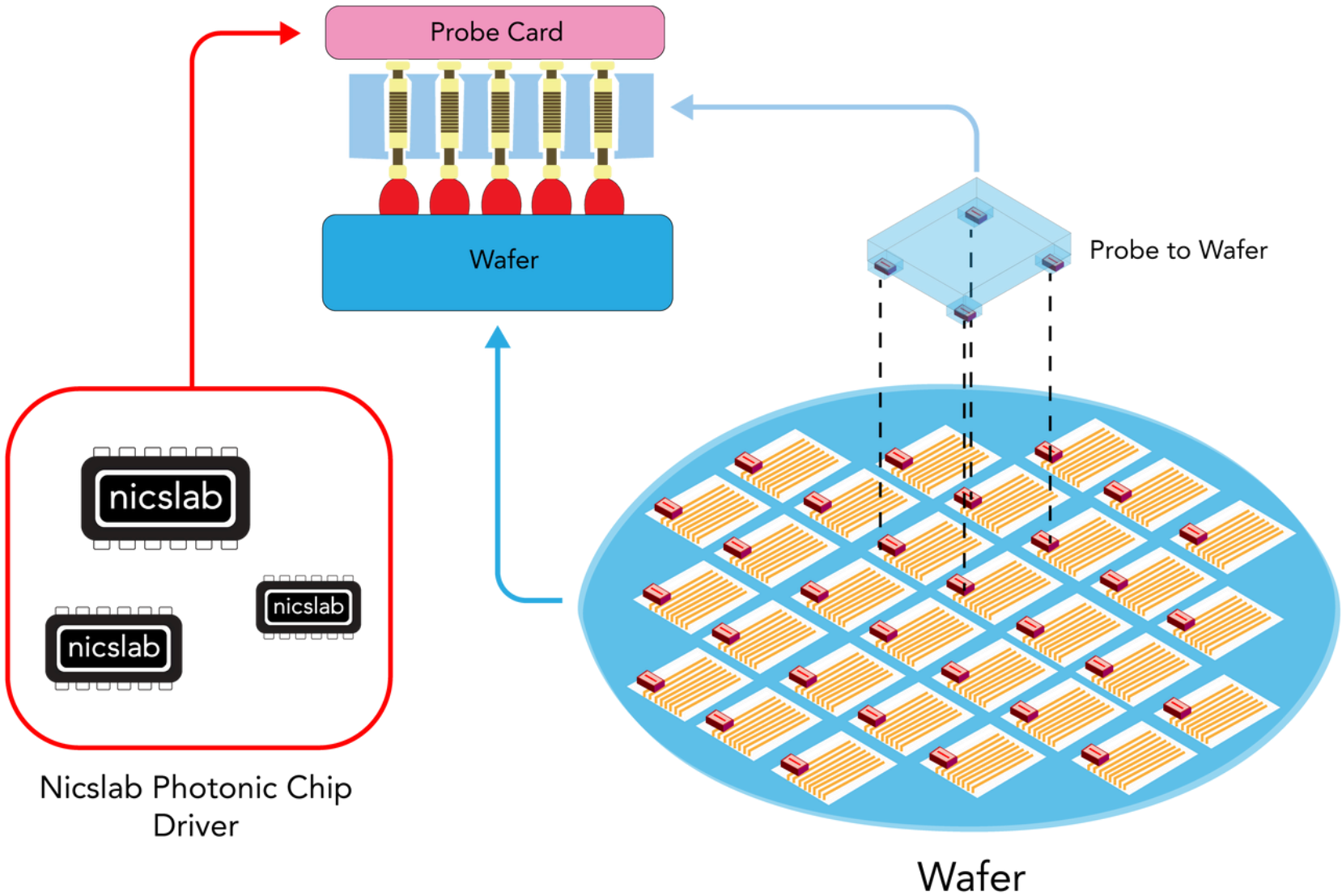

Semiconductor foundries

PUBLICATIONS

C. A. A. Franken et al. | UNIVERSITY OF TWENTE

"Hybrid-integrated diode laser
in the visible spectral range"

doi: 10.1364/OL.433636

Shihan Hong et al. | ZHEJIANG UNIVERSITY

"Ultralow-loss compact silicon photonic
waveguide spirals and delay lines"

doi: 10.1364/PRJ.437726

Nemanja Jovanovic et al. | CALTECH / JPL NASA

"An all-photonic, dynamic device
for flattening the spectrum of a laser frequency comb
for precise calibration of radial velocity measurements"

doi: 10.1117/12.2630301

Nemanja Jovanovic et al. | CALTECH / JPL NASA

"Flattening laser frequency comb spectra
with a high dynamic range, broadband spectral shaper
on-a-chip"

doi: 10.1364/OE.470143

Lu, Kaihang et al. | BEIJING UNIVERSITY

"Empowering high-dimensional optical fiber communications
with integrated photonic processors"

doi: 10.1038/s41467-024-47907-z

Gagino, M et al. | EINDHOVEN UNIVERSITY OF TECHNOLOGY

"Integrated optical phased array with on-chip amplification
enabling programmable beam shaping"

doi: 10.1038/s41598-024-60204-5

Qiu, Z et al. | EPFL UNIVERSITY

"Large-scale photonic chip based pulse interleaver
for lownoise microwave generation"

doi: 10.1007/978-3-031-63378-2_31

M. R. N. Afif et al. | NICSLAB OPS, INC.

"Simultaneous 1080-Channel Control
and Measurement for Photonic IC"

doi: 10.1364/OFC.2023.M3Z.16

CONTACT US

Please visit www.nicslab.com for further information, or you can get in touch with us as listed below:

California

Nicslab Ops, Inc.
228 Hamilton Avenue,
3rd Floor, Palo Alto
Silicon Valley, CA, 94301
United States

Email: support@nicslab.com
Phone: +1 (650) 521-9982

New York

Nicslab - Luminate
260 E. Main St., Suite 6380
Rochester, NY 14604
United States

Bandung

PT. Nicslab Global Industri
Menara Asia Afrika 9th floor
Jl. Asia Afrika No. 133-137,
Bandung West Java 40112
Indonesia

Email: nicslab.id@nicslab.com
Phone: +62 22 8602 6854

Book a meeting

<https://meetings.hubspot.com/andri-mahendra>



<https://www.nicslab.com>

support@nicslab.com

Phone: +1 (650) 521-9982

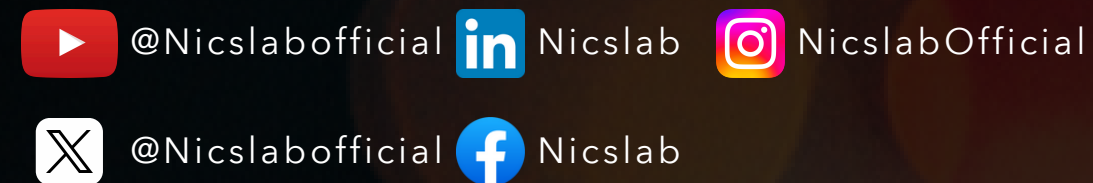

Hello,

It has been an honor for us to serve our customers and build the devices that help their work. We always put the users' needs first when we create the products.

When the challenge of the internet data traffic is undergoing a dramatic explosion, rapidly transitioning from gigabit system to petabit system generating massive amounts of data that can be analyzed to extract valuable information. Our revival for this challenge is to generate integrated solutions by providing hardware subsystems, automation software, and data interaction for users and devices in a manner that is easy to use, compact, productive, and cost-efficient. Whether measuring power usage, electrical signal, or factory controller to the internet, everyone wants it to be user-friendly, manageable, and accurate. And we can make this happen.

Nicslab is going to revolutionize communications at the speed of light for infrastructure in data centers, instrumentation, AI, and quantum computing with chip-scale integrated electronics and photonics.

Thank you.

Sincerely,

Andri Mahendra, PhD
Founder and CEO of Nicslab